



Royal Industrial Suppliers

Quality Fasteners Specialist

No. 4, M.G.S. Complex, Benki Nawab Street, S.P. Road Cross, Bangalore 560002

An ISO 9001:2015 Certified Co



8310165941 / 9008782885



sales@royalfastenersindia.com



www.royalfastenersindia.com

CATALOGUE NUMBER: **B1G45S**

SPRING WASHER SQUARE

DIN 7980

AISI 301 - BLACK

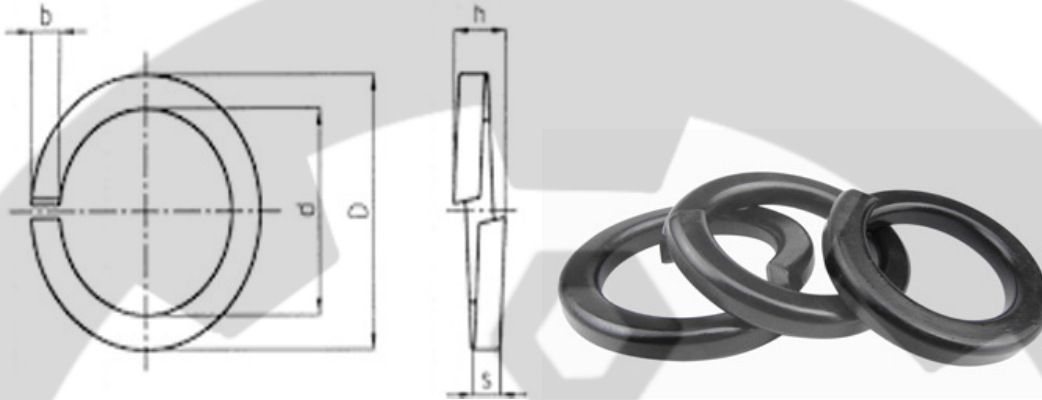

Send your Orders / Enquiries along with the following Item Codes

All Dimensions are in MM

Nominal Size Bolt Size ↓	PART NO.	Inside Dia d		Outside Dia	Height h		Section Width b		Section Thickness s	
		Min	Max	D Max	Min	Max	Min	Max	Min	Max
M3	B1G45S03000	3.10	3.40	5.60	2.00	2.36	0.90	1.10	0.90	1.10
M3.5	B1G45S30500	3.60	3.90	6.10	2.00	2.36	0.90	1.10	0.90	1.10
M4	B1G45S04000	4.10	4.40	7.00	2.40	2.83	1.10	1.30	1.10	1.30
M5	B1G45S05000	5.10	5.40	8.80	3.20	3.78	1.50	1.70	1.50	1.70
M6	B1G45S06000	6.10	6.50	9.90	3.20	3.78	1.50	1.70	1.50	1.70
M8	B1G45S08000	8.10	8.50	12.70	4.00	4.72	1.90	2.10	1.90	2.10
M10	B1G45S10000	10.20	10.70	16.00	5.00	5.90	2.35	2.65	2.35	2.65
M12	B1G45S12000	12.20	12.70	18.00	5.00	5.90	2.35	2.65	2.35	2.65
M14	B1G45S14000	14.20	14.70	21.10	6.00	7.10	2.80	3.20	2.80	3.20
M16	B1G45S16000	16.20	17.00	24.40	7.00	8.25	3.30	3.70	3.30	3.70
M18	B1G45S18000	18.20	19.00	26.40	7.00	8.25	3.30	3.70	3.30	3.70
M20	B1G45S20000	20.20	21.20	30.60	9.00	10.60	4.30	4.70	4.30	4.70
M22	B1G45S22000	22.50	23.50	32.90	9.00	10.60	4.30	4.70	4.30	4.70
M24	B1G45S24000	24.50	25.50	35.90	10.00	11.80	4.80	5.20	4.80	5.20
M27	B1G45S27000	27.50	28.50	38.30	10.00	11.80	4.80	5.20	4.80	5.20
M30	B1G45S30000	30.50	31.70	44.10	12.00	14.20	5.80	6.20	5.80	6.20